

*City of Leominster, Department of Public Works, Water Division
Public Water Supply ID # 2153000*

2010 DRINKING WATER QUALITY REPORT

The City of Leominster is dedicated to preserving the quality and reliability of its drinking supplies. In addition to continued source protection efforts and planned upgrades to its treatment facilities, the City has an aggressive flushing and water main replacement program. Further information about this report or any aspect of the public water supply can be obtained by contacting Charles Reed at 978-534-7590 / ext. 517 or e-mail: Creed@dpw.leominster-ma.gov

YOUR DRINKING WATER SOURCES

The City of Leominster lies entirely within the Nashua River basin. It encompasses about 30 square miles of land. Much of the western half of the city includes state forest, watershed lands, and other protected open space. The City obtains its drinking water from the Distributing Reservoir system, including Haynes and Morse Reservoirs; the Fallbrook Reservoir at Wachusett Street; the NoTown Reservoir system, including Goodfellow Pond and Simonds Reservoir; and the Southeast Corner Well Fields at Jungle Road. Leominster also has an emergency connection to the Wachusett Reservoir at Rte 110.

SOURCE WATER ASSESSMENT AND PROTECTION

In 2004 the Massachusetts Department of Environmental Protection (MassDEP) completed a Source Water Assessment and Protection (SWAP) report for the sources serving this water system. MassDEP assigned an overall susceptibility ranking of *high* to Leominster's water sources, based on the presence of at least one high threat land use within the water supply protection areas. The SWAP report commends the City of Leominster for actively promoting source protection through aggressive land acquisition, installation of sanitary sewers, and continued public education efforts

Where can I see the SWAP Report?

The SWAP report and map are available at the Leominster Water Division. The report can also be viewed online at www.mass.gov/dep/water/drinking/2153000.pdf

EDUCATIONAL INFORMATION

In order to ensure that tap water is safe to drink, the U.S. Environmental Protection Agency (EPA) and MassDEP prescribe regulations that limit the amount of certain contaminants in water provided by public water systems. Food and Drug Administration (FDA) and Massachusetts Department of Public Health regulations establish limits for contaminants in bottled water that must provide the same protection for public health. All drinking water, including bottled water, may reasonably be expected to contain at least small amounts of some contaminants. The presence of contaminants does not necessarily indicate that water poses a health risk. More information about contaminants and potential health effects can be obtained by calling the EPA Safe Drinking Water Hotline at 800-426-4791.

Sources of drinking water (both tap water and bottled water) include rivers, lakes, streams, ponds, reservoirs, springs, and wells. As water travels over the surface of the land or through the ground, it dissolves naturally occurring mineral, and in some cases, radioactive material. It can pick up substances resulting from the presence of animals or from human activity.

Contaminants that may be present in source water include:

Microbial contaminants -such as viruses and bacteria, which may come from sewage treatment plants, septic systems, agricultural livestock operations, and wildlife.

Inorganic contaminants -such as salts and metals, which can be naturally-occurring or result from urban stormwater runoff, industrial or domestic wastewater discharges, oil and gas production, mining, or farming.

Pesticides and herbicides -which may come from a variety of sources such as agricultural, urban stormwater runoff, and residential uses.

Organic chemical contaminants -including synthetic and volatile organic chemicals, which are by-products of industrial processes and petroleum production, and can also come from gas stations, urban stormwater runoff, and septic systems.

Radioactive contaminants -which can be naturally occurring or be the result of oil and gas production and mining activities.

Some people may be more vulnerable to contaminants in drinking water than the general population. Immune system - compromised persons such as persons with cancer undergoing chemotherapy, persons who have undergone organ transplants, people with HIV/AIDS or other immune system disorders, some elderly, and some infants can be particularly at risk from infections. These people should seek advice about drinking water from their health care providers. EPA/Centers for Disease Control guidelines on appropriate means to lessen the risk of infection by *Cryptosporidium* are available from the Safe Drinking Water Hotline at 800-426-4791.

If present, elevated levels of lead can cause serious health problems, especially for pregnant women and young children. Lead in drinking water is primarily from materials and components associated with home plumbing. The Leominster Water Division is responsible for providing high quality drinking water, but cannot control the variety of materials used in plumbing and plumbing components. When your water is unused for several hours, you can minimize the potential for lead exposure by running your tap for 30 seconds to 2 minutes before using water for drinking or cooking. If you are concerned about lead in your water, you may wish to have your water tested. Information on lead in drinking water, testing methods, and steps you can take to minimize exposure is available from the Safe Drinking Water Hotline or at (<http://www.epa.gov/safewater/lead>). Please feel free to call Charles Reed 978-534-7590 ext 517 or email at creed@dpw.Leominster-MA.gov.

WATER SYSTEM COMPLIANCE

The City is continuing to operate under an Administrative Consent Order (ACO) with MassDEP to correct certain problems and bring the City's water system back into compliance. Leominster Water Division, working closely with Veolia Water and Woodard & Curran, has made modifications to Notown Treatment Plant that have had significant success removing precursors that cause trihalomethanes to form in the distribution system. Further modifications are planned to start in 2011. The new plant at Distributing Reservoir went into operation May 2010 and has been producing water of an extremely high quality ever since.

Fallbrook Treatment Plant was modified in 2009 to remove seasonal manganese with great success. In 2010 the Fallbrook Reservoir water intake was raised with the result that even the raw water has very little manganese being detected. Manganese continues to be closely monitored. The Southeast Wells are scheduled for major upgrades in 2011 that will result in higher quality water being produced at that source.

To help us provide the highest quality water available to our customers, the Water Division has an ongoing operator training program that encourages staff to achieve the highest qualifications in the field as possible. In addition, the reservoirs and wells are policed by a reservoir guard to prevent vandalism and potential contamination of drinking water. A forestry management program has begun to harvest mature trees and cleanup ice storm damage in an effort to manage the watershed properly and prevent forest fires. Old cast iron water mains continue to be changed by the Department, and a semi-annual water main flushing program continues.

IMPORTANT DEFINITIONS

Maximum Contaminant Level (MCL) – the highest level of a contaminant that is allowed in drinking water. MCLs are set as close to the MCLGs as feasible using the best available technology.

Maximum Contaminant Level Goal (MCLG) – the level of a contaminant in drinking water below which there is no known or expected risk to health. MCLGs allow for a margin of safety.

Treatment Technique (TT) – A required process intended to reduce the level of a contaminant in drinking water.

Action Level (AL) – The concentration of a contaminant, which, if exceeded, triggers treatment or other requirements, which a water system must follow.

Range: This column shows the lowest and highest values found in our tests.

90th Percentile: Lead and copper compliance is based on the 90th percentile value, which is the highest level found in 9 out of every 10 homes sampled. This number is compared to the action level for each contaminant

Unregulated Contaminants: Unregulated contaminants are substances without MCLs for which EPA requires monitoring. For some of these substances, the Massachusetts Office of Research and Standards (ORS) has developed state guidelines or secondary MCLs.

Secondary Maximum Contaminant Level (SMCL): These standards are developed to protect the aesthetic qualities of drinking water and are not health based.

Office of Research and Standards Guideline (ORSG): This is the concentration of a chemical in drinking water, at or below which, adverse health effects are unlikely to occur after chronic (lifetime) exposure. If exceeded, it serves as an indicator of the potential need for further action.

Maximum Residual Disinfectant Level (MRDL): The highest level of a disinfectant allowed in drinking water. There is convincing evidence that addition of a disinfectant is necessary for control of microbial contaminants.

Maximum Residual Disinfectant Level Goal (MRDLG) -- The level of a drinking water disinfectant below which there is no known expected risk to health. MRDLGs do not reflect the benefits of the use of disinfectants to control microbial contaminants.

ppm = parts per million, or milligrams per liter (mg/l)

ppb = parts per billion, or micrograms per liter (µg/l)

pCi/l = picocuries per liter (a measure of radioactivity)

NTU = nephelometric turbidity units

WATER QUALITY TESTING RESULTS

The following test results were from monitoring performed during 2010 or during the most recent sampling period for each contaminant group, as required by MassDEP. Only detected contaminants in finished water are shown.

Bacteria Detections	Highest % Positive in a Month	Total # Positive	MCL	MCLG	Violation (Y/N)	Possible Source
Total Coliform	1.6 %	1	>5%	0	N	Naturally present in the environment
E.coli	0 %	0	*	0	N	Human and animal fecal waste

* Compliance with the E.coli MCL is determined upon additional repeat testing.

Lead and Copper	Date Collected	90th Percentile	Action Level (AL)	MCLG	# of sites sampled	# of sites above AL	Exceeds AL (Y/N)	Possible Sources
Lead (ppb)	8/20/08	5	15	0	31	1	N	Corrosion of household plumbing
Copper (ppm)	8/28/08	0.4	1.3	1.3	31	1	N	Corrosion of household plumbing

Regulated Contaminants	Date(s) Collected	Highest Result or Highest RAA*	Range Detected	MCL or MRDL	MCLG or MRDLG	Violation (Y/N)	Possible Sources
Inorganic Contaminants							
Nitrate (ppm)	6/10/2010	0.46	0.01 - 0.46	10	10	N	Runoff from fertilizer use; leaching from septic tanks; natural deposits
Perchlorate (ppb)	8/31/2010	0.14	----	2	----	N	Fireworks, firearms, blasting
Fluoride (ppm)	6/1/2010	0.12	0.10 – 0.12	4		N	Naturally occurring
Barium (ppm)	6/1/2010	0.011	<0.007 – 0.011	2	2	N	Erosion of natural deposits
Disinfection Contaminants							
Haloacetic Acids (HAA5s) (ppb)	Quarterly	28	0 – 72.0	60	--	N	Byproduct of drinking water disinfection
Total Trihalomethanes (TTHMs) (ppb)	Quarterly	43	0 – 99.5	80	--	N	Byproduct of drinking water chlorination
Chlorine (ppm)	60 samples per month	0.43	0.07 – 1.70	4	4	N	Water additive used to control microbes
Synthetic Organic Contaminants							
Atrazine (ppb) -Southeast Wellfield only	Quarterly	0.16	0– 0.16	3	3	N	Runoff from herbicide applications

Unregulated and Secondary Contaminants	Date Collected	Highest Detected Amount	Average	SMCL	ORSG	Possible Sources
Manganese (ppb)	5/13/2010 & 6/1/2010	25*	15	50	---	Erosion of deposits
Sodium (ppm)	6/1/2010	15**	13	--	20	Natural sources; runoff from road salt
Sulfate (ppm)	6/1/2010	9.8	4.9	250	--	Natural sources

* The EPA has established a lifetime health advisory (HA) value of 300 ppb for manganese to protect against concerns of potential neurological effects, and a one-day and 10-day HA of 1000 ppb for acute exposure.

** Sodium-sensitive individuals, such as those experiencing hypertension, kidney failure, or congestive heart failure, should be aware of sodium levels in their drinking water where exposures are being carefully controlled.

Turbidity is a measure of the cloudiness of the water. We monitor it because it is a good indicator of water quality.

Distributing Water Treatment Facility (Before Filtration Plant was in Operation)	MCL	Highest Detected Daily Value	Highest Monthly Average	Violation (Y/N)	Possible Source of Contamination
Turbidity (NTU)	1	0.76 *	0.55	N	Soil runoff
*The turbidity MCL applies to unfiltered systems that MassDEP has determined in writing that filtration is required. The monthly average must be less than the MCL to meet compliance standards.					
Distributing Water Treatment Facility (After Filtration Plant was in Operation)	MCL	Lowest Monthly % of Samples	Highest Detected Daily Value	Violation (Y/N)	Possible Source of Contamination
Turbidity (NTU)	1	-----	0.48	N	Soil runoff
Monthly Compliance**	At least 95% < 0.3 NTU	99.97	-----	N	
NoTown Water Treatment Facility (Filtered)	TT	Lowest Monthly % of Samples	Highest Detected Daily Value	Violation (Y/N)	Possible Source of Contamination
Daily Turbidity Compliance (NTU)	1	-----	0.54	N	Soil runoff
Monthly Compliance**	At least 95% < 0.3 NTU	99.79	-----	N	
Fallbrook Water Treatment Facility (Filtered)	TT	Lowest Monthly % of Samples	Highest Detected Daily Value	Violation (Y/N)	Possible Source of Contamination
Daily Turbidity Compliance (NTU)	1	-----	0.59	N	Soil runoff
Monthly Compliance**	At least 95% < 0.3 NTU	99.63	-----	N	
**Monthly turbidity compliance is related to a specific treatment technique (TT). This treatment facility filters the water so at least 95% of our samples each month must be below the turbidity limits specified in the regulations.					

CROSS CONNECTION INFORMATION FOR RESIDENTIAL CUSTOMERS

As users of a shared valuable resource, we should all be aware of the potential for drinking water contamination by cross connection. A cross connection occurs whenever a pipe or hose is placed in any container or machine, such as a hose placed in a pool or a pipe feeding a lawn sprinkler system.

When there is a reverse flow, caused by a water main break or other sudden loss of pressure, the drinking water pipes may get contaminated with whatever the line was feeding – such as pool water, fertilizers, or pesticides. This can be avoided by installing the proper backflow prevention device for a given application or maintaining an air gap between the outlet and the container being filled.

Hose Bib Vacuum Breakers are simple, low-cost devices that should be used to help prevent backflow of water when using water hoses. They are easy to install and available at many plumbing supply stores.



hose bib vacuum breaker

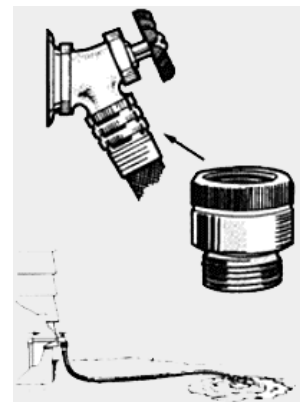

For more info, call Charles Reed at 978-534-7590, extension # 517.

City of Leominster
Water Division
109 Graham Street
Leominster, MA 01453

PUBLIC PARTICIPATION

The Leominster Water Division recognizes that it exists to meet the needs of its customers and welcomes comments from any person it serves. Please feel free to call at 978-534-7590 / ext. 517. For customers wishing to be more involved in the affairs of the Leominster Water Division, a Leominster City Council Water Oversight Committee oversees Water Division operations. The public is welcome to attend.

El informe contiene información importante sobre la calidad del agua en su comunidad. Tradúzcalo o hable con alguien que lo entienda bien.

Le rapport contient des informations concernant la qualité de l'eau de votre communauté. Faites-le traduire, ou parlez-en à un ami qui le comprend bien.